



AURORA
RALLY EQUIPMENT

WE ARE AURORA



About



FB



Insta

Welcome to Aurora, where adventure meets precision. We don't just create rally gear; we engineer experiences. Rooted in the heart of rally racing, we grasp the challenges of rugged terrains and the thrill of the unknown. Our legacy is etched on trails of the world's toughest races. From Dakar's gruelling tracks to Africa Eco Race's unforgiving sands, our gear doesn't just endure; it triumphs.

Each component, meticulously crafted, bears the mark of our unwavering commitment. Aurora beckons those who defy convention, who push adventure's boundaries. It's not just about machines; it's about stories, challenges, and victories. Join us on this extraordinary journey, as we forge a new era in rally gear.

Get ready for an adventure like no other, as the DesertX becomes the next chapter in a saga of legendary machines.

NAVIGATE THROUGH HISTORY



History

2013

Aurora comes to life!

Creating the first rally roadbook holder with magnetic transmission, IP67 rating, removable interior, polymer o-rings that never break and crashproof shell.

2014

Winners!

First International rally win with Pål Anders Ullevålseter, 11 times Dakar participant and 2nd in 2010.

2015

Winners!

Africa Eco Race winners with Pål Anders Ullevålseter and FIM world champions with Anastasiya Nifontova.

2017

Support team for the 1st and 2nd place riders. Gev Sella and Pål Anders Ullevålseter respectively. Stefan Svtiko wins Serres Rally 2015.

2016

Winning streak!

1st and 2nd in Africa Eco Race with Pål Anders Ullevålseter and Andrew Newland. Entering the Adventure market with the Aurora Xplorer. The only rally conversion kit with CNC billet brackets.

2018

Winning Morocco Desert Challenge with Joakim Lundby and his Aurora Xplorer.

2019

Moved to a new 500sqm (5400 square feet) building. Prototyping, R&D and key manufacturing areas are now all in house. Investing heavily in rapid prototyping techniques.

World Domination: Anastasiya Nifontova becomes the first woman in the world to complete Dakar in Malle Moto class with Aurora Roobook. First participation in EICMA Milan with new products for the Adventure market!

2020

Winning Africa Eco Race with Alessandro Botturi.

R&D Expansion. Adding two +/-200g accelerometers in our laboratory quiver. Analysed data are fed up in our CAD software and predict the fatigue life of the parts. Back to back virtual testing allows us to race multiple events and see the effects. Results? Better, more reliable, lighter, and safer components!

2021

Precision reigns in the rally arena with our meticulously crafted full CNC tower. Weighing just over 1kg, it stands as the most robust tower to date, a testament to Aurora's commitment to strength and durability. In the Enduro market, we've introduced a game-changer: a **complete CNC frame clamp**. It boasts a unique feature - internal spacers that shield the bike's frame, setting it apart as the only clamp of its kind in the world.

From previous page!

2022

Revolutionary Superlight kit unveiled! The **full CNC tower** now weighs a mere **848 grams**, an engineering feat driven by years of acceleration data. Versatile tuning options cater to racing, commuting, or travel needs, while the fine-tuned center of gravity enhances performance. It introduces a groundbreaking 3D resin printed cable cover, seamlessly integrated.

Aurora's patent-pending **Screen Safety System (S³)** elevates safety and ergonomic standards. The Puig™ shield, combined with S³, grants the screen dynamic movement upon impact, a game-changer in rider safety and customization.

Obtaining the **peel3D laser scanner**, a vital addition to our toolkit. Alongside the **FARO metrology arm**, it accelerates our digital bike library, revolutionizing design and production speed.

2023

Obtaining another Peel 3 laser scanner to turbocharge R&D. Streamlining reverse engineering for precise part fitment. Peel's cutting-edge scanners and software digitize bikes swiftly and seamlessly.

The **Ducati DesertX** is a showstopper at Hellas Rally bivouac. With iconic Dakar aesthetics, it's an instant sensation. Enter the **DesertXpress**: Carbon Fiber tank, DNA high performance air-filter, monoblock tower, ram air duct, and upgraded air intake. Our rider, Stefanos Theoharis, pushed it to the limit at Hellas Rally 2023, battling brutal conditions.

Now, we're onto the next innovation. Read on as you are ready to embark the DesertXpress!

To next page!

Anything is possible!





DesertXpress details



Download the brochure

LIGHTER, COOLER, FASTER



The DesertXpress, a feat of meticulous engineering, redefines the large adventure bike experience. With a lightweight full carbon fiber tank that maintains low temperatures, even under extreme conditions, it's a game-changer. This tank is the first of its kind, hosting a dedicated passage for the DNA High Performance air filter, enhancing ergonomics and performance.

A revamped forced direct intake system ensures a continuous supply of cold air, even at low speeds. Choose between keyless or keyed options for the aluminum fuel cap. The bi-directional CNC breather eliminates fuel pump vapor lock. With minimal attachments, the all-carbon side panels are easily removable, minimizing service time. The Baja Designs LP4 LED light illuminates night rides. Versatile setups, from OEM to aftermarket options, cater to diverse preferences and ensure that night rides are a delight.

More than just a bike, it stands as a testament to our unwavering pursuit of excellence. The DesertX sets a fresh benchmark, encouraging riders to venture into uncharted territories with assurance and finesse—an authentic symbol of Ducati's off-road heritage.



RUGGED, READY, RELENTLESS

Drawing on years of championship-winning expertise, Aurora Rally Equipment redefines excellence in Rally and Adventure Bike Equipment. Our kits seamlessly transform Off-road and Adventure bikes into powerhouses, primed for global racing challenges and epic off-road adventures. At Aurora Rally Equipment, we don't just design and test our products; we race them. Trusted by top Rally riders in the most gruelling events worldwide, our equipment is battle-tested for ultimate performance. Elevate your ride with Aurora - where passion meets precision.

Aurora goes rally racing!

When the rally calls, answer with confidence. Our kit isn't just born from expertise; it's battle-tested in the 2023 edition of Hellas Rally. The bike was equipped with everything a rally rider can ask for in the event of unexpected hiccups. From chemical lights and tank repair kits, to self-sealing tape, epoxy, duct tape and spare ty-raps. But we didn't stop there. Our kit goes beyond the basics. Automatic fuses and accelerometers transform the ride into a scientific marvel gathering crucial data for future development. This isn't just a kit; it's a revolution in Rally preparation.



Critical Know How





FORCED DIRECT INTAKE (FDI)

The custom build Direct Air Intake is a technological marvel, featuring a meticulously designed 3D printed intake. This innovative system channels air directly towards the air filter, ensuring consistent supply of cool, oxygen-rich air that enhances the bike's overall performance.

What sets this intake apart is that it is printed using Selective Laser Sintering technique to long term durability and strength, and the metallic mesh can be sealed off when traversing challenging terrains or there is a high-pollution situation. The flexible tubing is routed so that the water is trapped in its lower part and then evacuated to the ground using a Tygon hose. The outlet that feeds air to the air filter is also sealed with a nylon mesh that acts an additional layer of protection to ensure that the air filters are not overloaded during pure off-road riding.



THE CONCEPT

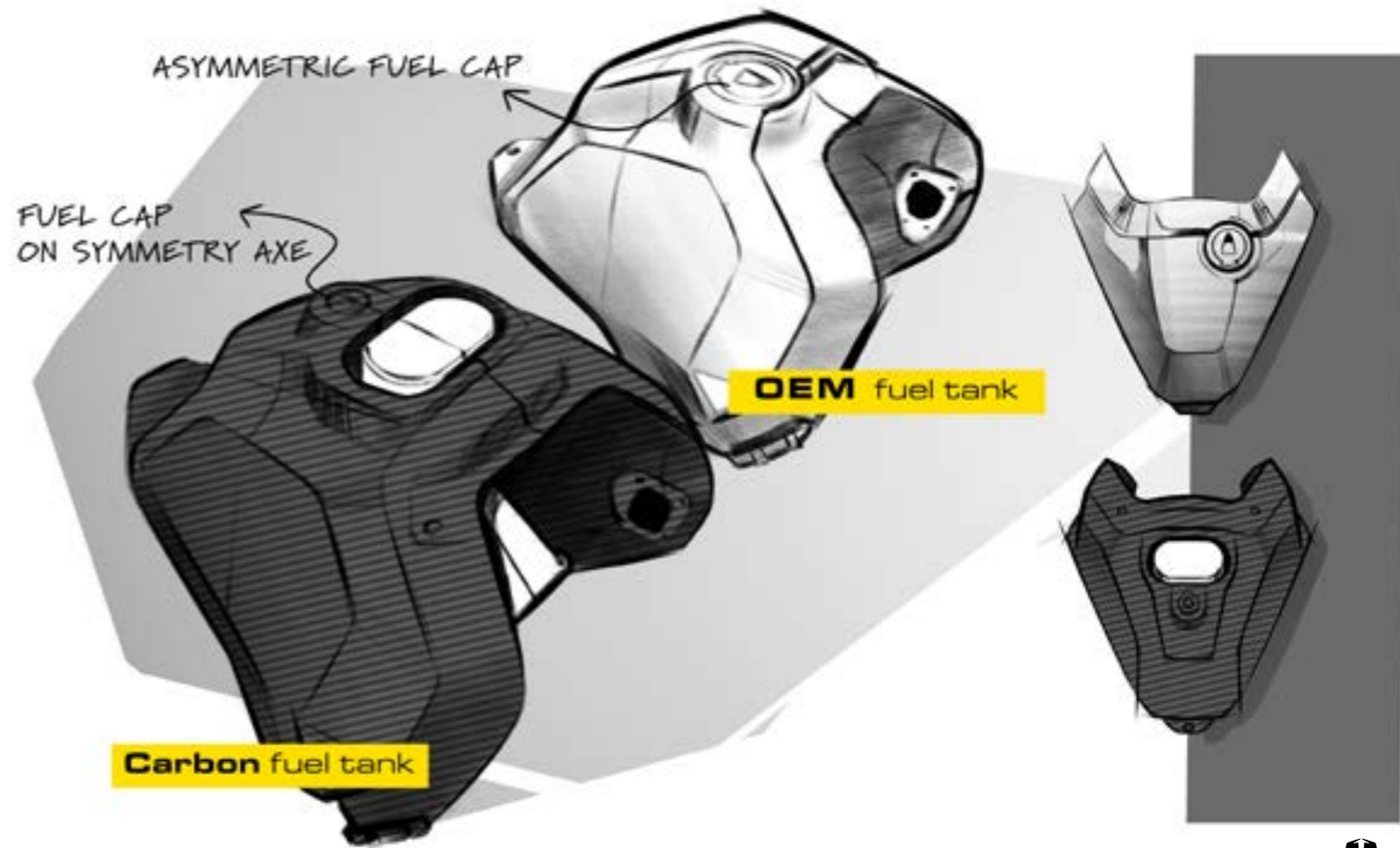
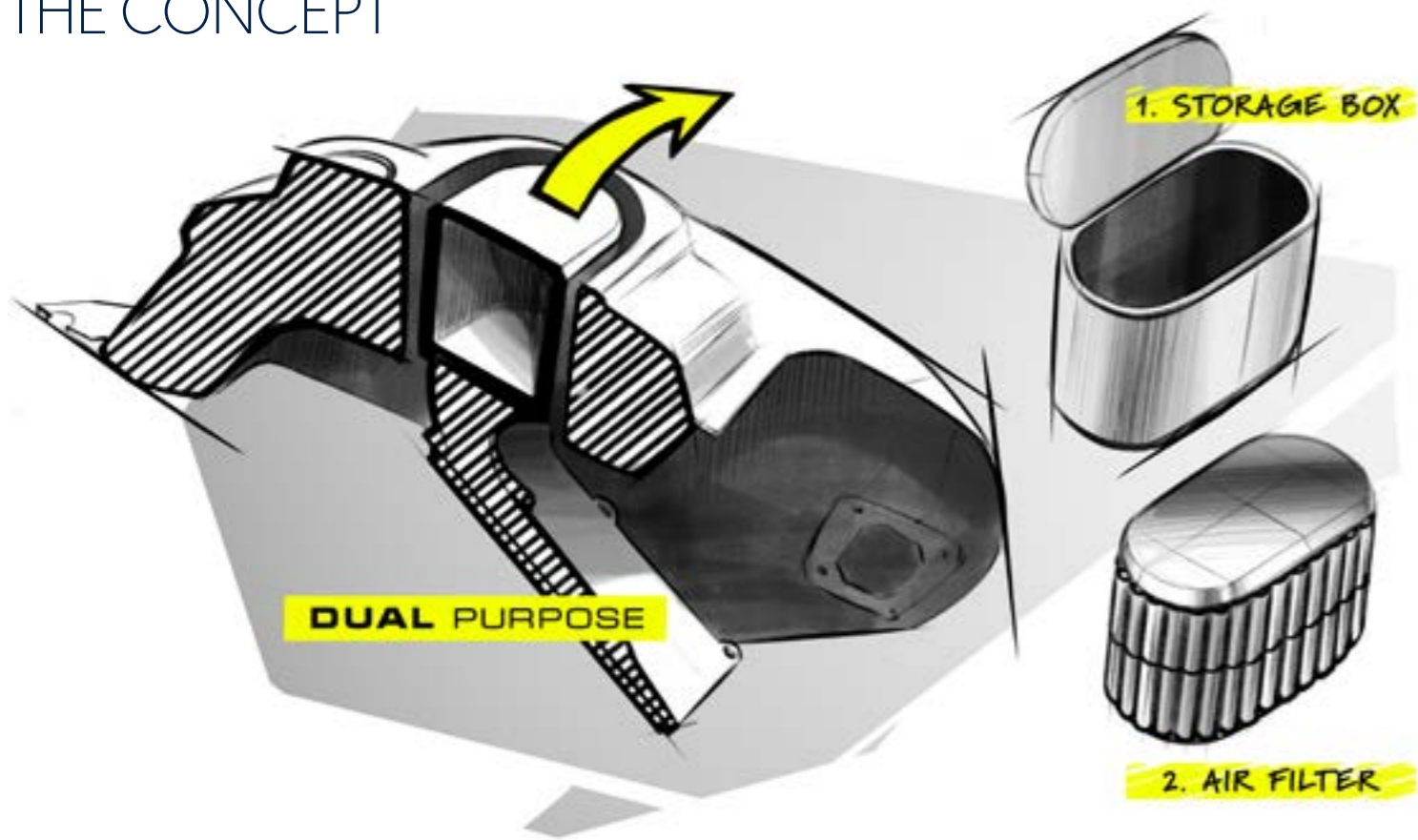

Air intake development

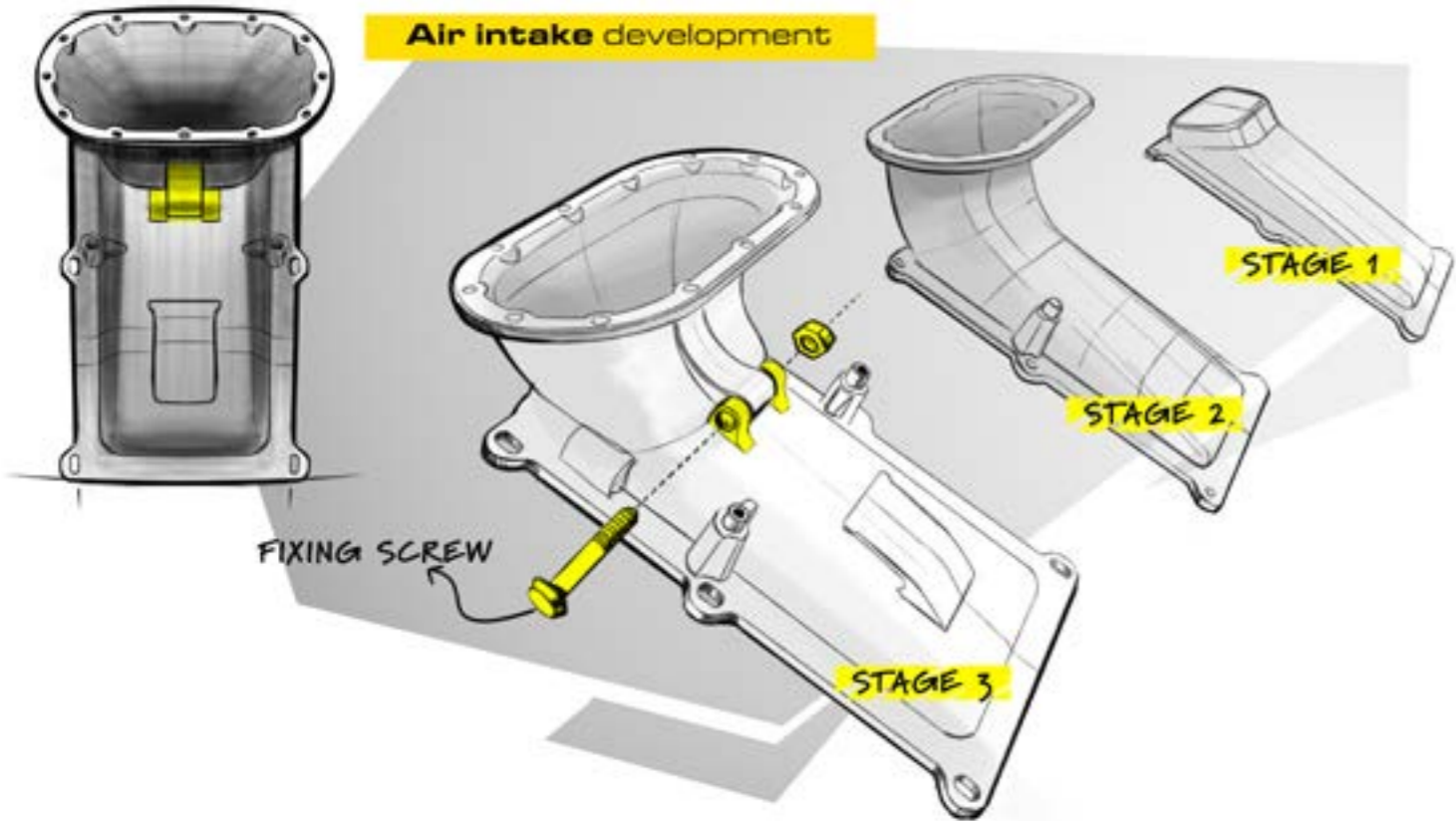

Easy removal ↑

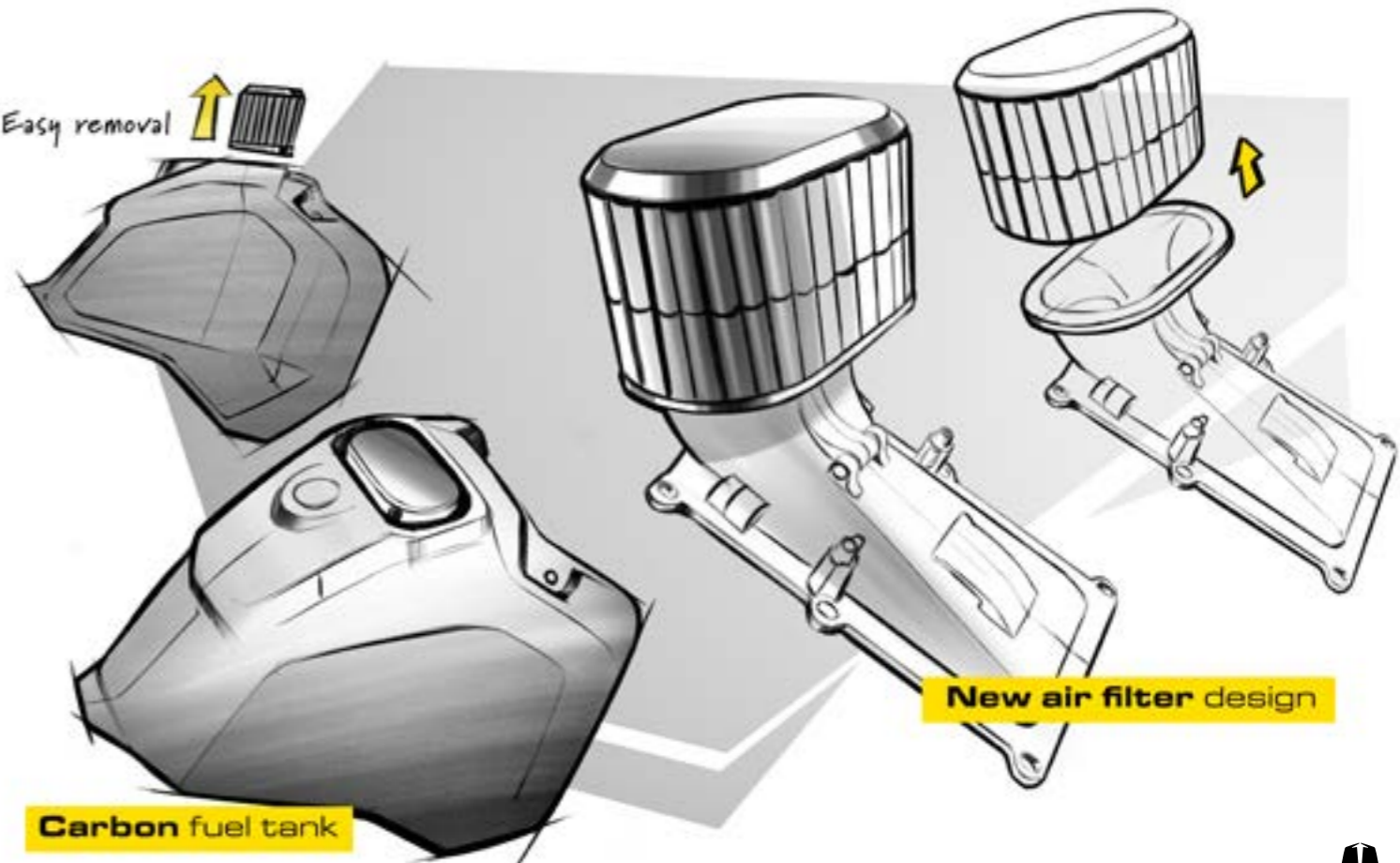

THE CONCEPT

In the heart of every adventurer lies the spirit of self-reliance, the ability to conquer challenges head-on. That's why we crafted a fuel tank for the DesertX that empowers you to take charge, right there in the field. Forged in collaboration with the trailblazers at DNA High Performance air filters, and the master craftsmen at CFCP, renowned for their artistry in handmade carbon parts. This is not just a composite fuel tank. It's a two-stage filtration powerhouse. Sporting a 19-liter capacity, it's a mere two liters shy of the OEM unit, yet it eclipses in both form and function. Crafted from cutting edge carbon, it's fortified with precision-machined aluminum billet CNC inserts, strategically placed for unparalleled strength. The removable front mounting point ensures that the tank flexes back from any crash, undeterred. Thanks to CFCP's groundbreaking variable carbon layers, it's an engineering marvel of strength and flexibility in one. This is a testament to our motto: 'Anything is possible'.

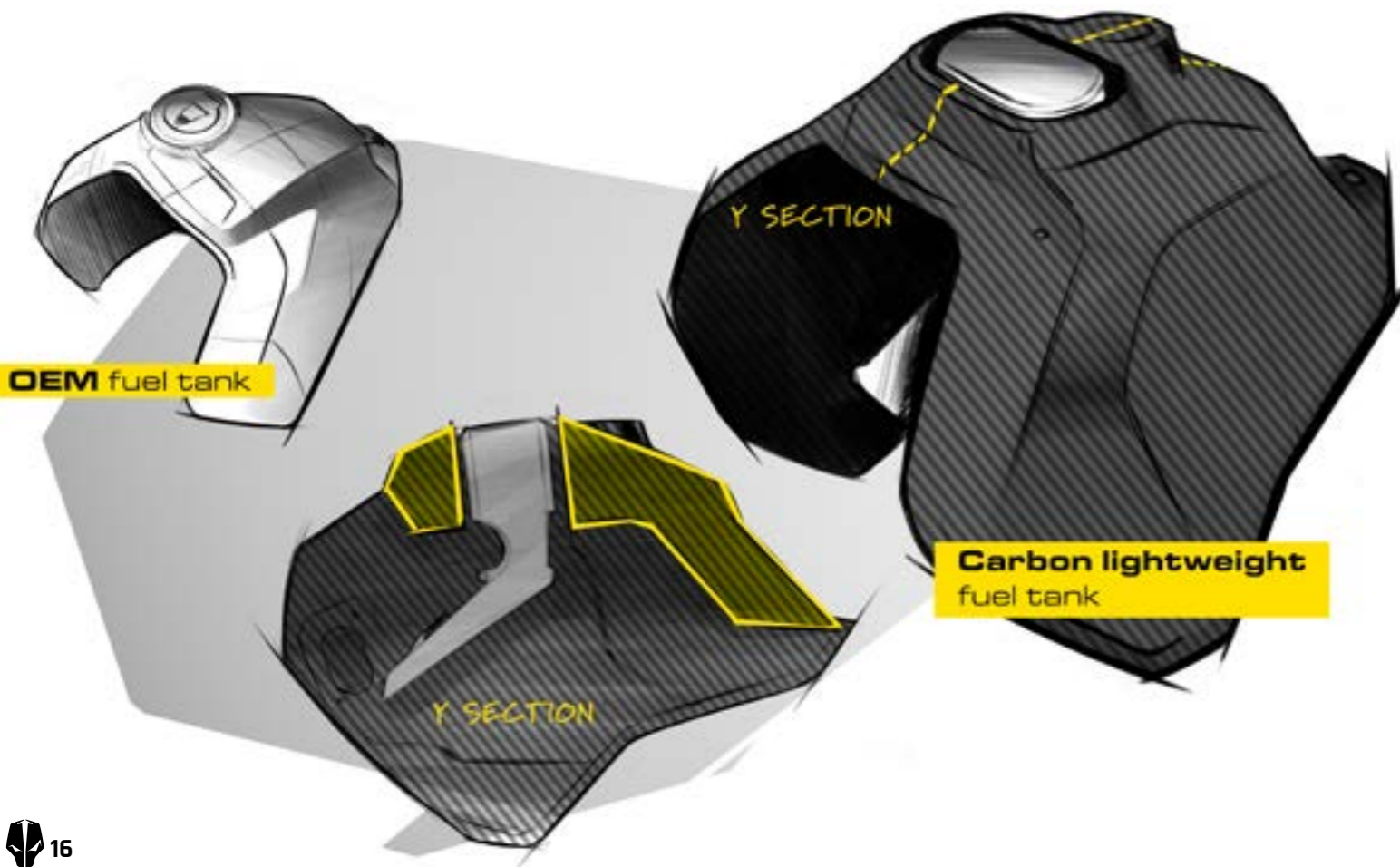

ALL CARBON TANK (ACF)

CFCP Fuel Tank

Our Carbon Fiber Tank is a game-changer for the DesertX. Shedding a substantial 5kg compared to the OEM unit, it significantly reduces the overall weight, bringing the center of gravity lower.

Cooler

This tank's advanced thermal properties keep temperatures in check, ensuring consistent performance and better ergonomics even in the most demanding conditions. You will not only notice the difference in weight, but also in the way the DesertX handles, giving you an edge in any rally or adventure scenario.

Afraid of crashing?

The tank was used and abused in Hellas Rally 2023 and was crashed heavily in rain conditions. It never lost fuel and it will come with an extra outer (removable) layer of Carbon Fiber to further improve its crash resistance.



IMAGINE. THE PERFECT INTAKE

Be Safe.

There is not one, but two high quality, DNA High performance air filters. Unlike other aftermarket air filter boxes which replace the OEM intake with a different setup, we went the opposite way. The OEM part was redesigned to accommodate the DNA air filter and our intake extension. Having an aftermarket filter in the OEM position means that even if you have structural damage on the top part of the bike, heavy pollution etc. the 2nd stage will still clean the air and save your engine.

Be quick!

Swapping air filters now is a two minute job. You do not even have to come off the bike to do it!

Be Cool.

The air from the engine can now escape from the tank, getting the bike to run cooler. Does not matter if you leave the bike in the sun anymore. Carbon will stay cool.

Be clever.

Swap the 1st stage with a storage box if you don't use the bike off road or if you simply want more room for your everyday use. This unique feature is a must have add on, as the DesertX has no room under the seat.



SINGLE PIECE NAV TOWER.

It's not a gadget; it's your secret weapon for conquering the desert. Elevate your game with the Monoblock Navigation Tower, setting a new benchmark for rally desert sports.

The tower was designed from the ground up, using millions of data from our accelerometer library. The tower is strong, easy to install and take off while the monoblock design reduces the weight of the tower further, while it maintains its strength and durability.

Just 200grams heavier than its plastic counterpart, the tower has a characteristic shape and it does not change the turning radius of the bike allowing you to be agile when the going gets tough.

Don't be afraid to push it, because this tower is able to accommodate anything you may ask. Moving the OEM instrument on the bars, not only protects the device, but allows you to install a full 10" tablet and a GPS (or mobile phone) on the tower and still have optimum ergonomics. See the difference.

Never give up!



LIGHTS BEYOND BELIEF

In the world of off-road racing, lighting transcends mere visibility; it's an absolute safety imperative. Enter the LP4 by Baja Designs™ - a groundbreaking LED light. When equipped with a pair of LP4s, you're greeted with a remarkable 17,500 lumens, a pinnacle of luminosity within our rally kits.

Paired with our ingenious Direct Air Intake, you're presented with a staggering array of over 14 lighting configurations. These range from the OEM LEDs for standard road legality to maximum power (utilizing two LP4s) or minimal weight (opting for a single Hella LED with the Direct Air Intake).

Switching between these setups is a breeze, taking mere minutes, whether you're cruising the streets or tearing through rugged off-road terrains. Illuminate your journey with the unmatched brilliance of Baja Designs™, and revolutionize your off-road racing experience!



THE SCIENCE BEHIND THE PROJECT.

The bike it is fully undressed and scanned with a FARO Quantum metrology scanning arm. This device has 7 axis of rotation , 2.4m reach in diameter and a volumetric accuracy of +/-0.025mm (single point 0.018mm). Human hair can be as thick as 0.016 to compare. All the key areas that mechanical clamping and assembly is required are scanned with this arm. Then a PEEL 3D laser scanner is

employed to fully digitize the whole bike and reverse engineer surfaces and geometries with ease. With an accuracy of 0.25mm/m the scanner allows us to fully digitize a motorbike in one day. CAD, Simulate, 3D print, CNC are our everyday tasks at Aurora. Our goal is push the boundaries and design, test and manufacture parts that never existed before.

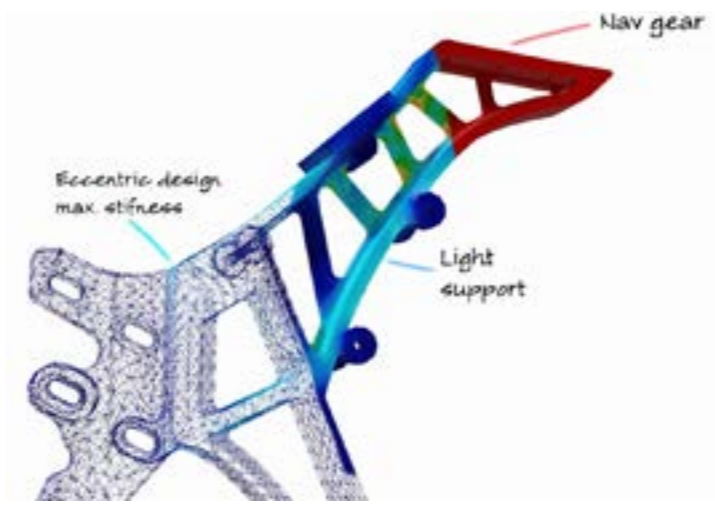

Digital fatigue testing of the monoblock tower.



Scanned model with Peel 3D



Evolution of the dual air intake.



Scanned model of the Carbon Fiber Tank to check geometry.

SAY HELLO TO A.D.A.M.

Digital world these days is amazing. Incorporating techniques straight from the domain of Formula 1, we've embarked a journey of virtual testing, simulating forces to identify weak points in the structures. Gathering acceleration data from the races we are able to simulate these forces on our parts and see when and if they will fail. Improve the CAD models and then re-run the simulations until we are happy with the result. Then back up the data by going racing! Race two Eco Races back to back? That's no problem for our CAD stations.

A.D.A.M. (Aurora Dynamic Analysis Module), a software born in-house, is developed for the explicit purpose of analyzing acceleration data, ADAM meticulously calculates frequencies, g-forces and gathers statistical data for reverse frequency analyses (i.e. you feed the forces and ADAM (v2.0) 'guesses' what type of terrain that riding may be). With over 120 million data points potentially generated in a mere ten hours of ride time, traditional processing methods fall short. ADAM accurately calculates peak acceleration figures, but also flagging any anomalous data that demands attention.

There are no industry standards for such parts. We set our own and we make sure that every component surpasses them. At Aurora we don't just innovate; we engineer excellence.

Peak acc. and time
Global Maximum g Force

statistics
All data
Zoom in to max
Data id
Check max peak time
Time
Zoom to min

Frequency report.
Used for vibration and fatigue analysis.

Frequency calculator

Main window
- data input
- statistics
- error logging
- progress analysis

seeing acceleration in 3 dimensions
3D g force representation

Understanding the global peak acceleration
2D g force representation

ADAM - AURORA DYNAMIC ANALYSIS MODULE

File check: Status: Ready to roll

Date read filter:

Gathering Files:

File number: Points per file: File with max g: Global Max:

Total Time: Points analysed: Average g: Global Min:

Progress: Files analysed: Discard Files:

Force Analysis Reading Files Calculating Units

Run Run One File

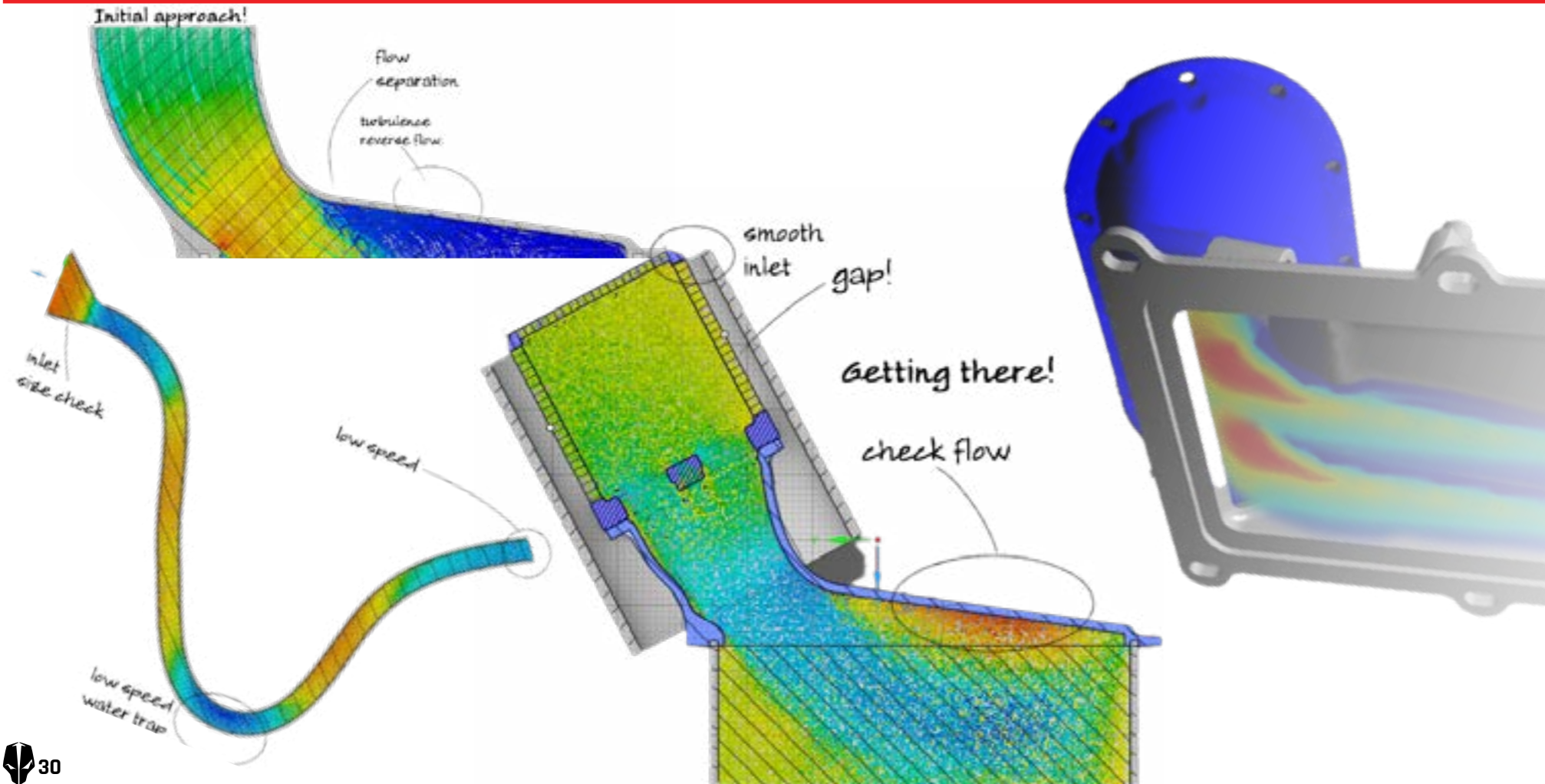

INTAKE EXCELLENCE THROUGH CFD!

In crafting the DesertX, we left no stone unturned in pursuit of optimal performance. Our meticulous approach led to a pivotal component: the intake system. Through Computational Fluid Dynamics (CFD), we delved into the intricacies of airflow, dissecting every nuance.

Flow dynamics were scrutinized, ensuring a seamless channelling of air. By mitigating flow separation, we eliminated turbulence, unlocking a smoother, more efficient intake process. This meticulous optimization extended to both flow and volume. Through precise adjustments, we achieved a harmonious balance, enhancing power delivery and responsiveness.

The result? A DesertX that breathes with unparalleled precision, characteristic noise, and excellent air quality. This CFD-driven refinement stands as a testament to our passion for crafting extraordinary experiences.

HANDCRAFTED CARBON CREATIONS by CFCP

Where tradition meets innovation, a skilled artisan at CFCP adds a personal touch to every carbon piece that is on our bikes. Here, technology and human touch harmonize. This is not just about production; it's about passion and dedication. With precision and care, our craftsman transforms raw carbon into a masterpiece, while understanding the material on the highest level. Each curve, each contour, is a testament to the artistry and skill embedded in each and every creation. Owning a piece crafted by CFCP means having a piece of a journey, reminding us that the essence of true craftsmanship lies in the hands that shape it.



*Attention to detail.
Always.*

RACING.

Racing isn't just about speed. It's about perfection, about pushing limits. That's why, when it comes to crafting parts for the Ducati DesertX, racing is at the heart of what we do. Racing helps us understand how our parts perform under the most extreme conditions and validate our theoretical models.

So when you ride a Ducati DesertX with our parts, you are not just riding a bike; you're riding the result of countless hours of dedication, of races won and lessons learned. Because for us, racing is not an option; it's an integral part of our promise to deliver excellence, every time you hit the road.



UNDER PRESSURE

Racing demands precision and poise under pressure. Hellas Rally 2023 posed the ultimate challenge for our DesertX. Extreme muddy conditions meant that each day brought crashes, repairs, and busy activity in the bivouac.

Yet, our bike demonstrated **unparalleled performance**. From the extended main harness to the carbon fiber tank, the DNA High performance air filter, nav tower, and electronic fuses—every component functioned seamlessly. This flawless operation enabled us to effortlessly gather crucial data from the bike on a daily basis for further improvements before each part goes into production.



POWER V2



Lighter, Faster, Fiercer

Engineered for victory



Anything is possible!



DISCLOSURES



Blog



Critical Know How



FAQ

HELLA is a trademark of HELLA GmbH and Co. KGAA
Ducati and **Ducati Corse** are figurative and denominative trademarks of Ducati MotoHolding S.p.A.
Baja Designs is a trademark of Bestop Baja LLC.
RAM MOUNTS is a trademark of National Products, Inc.
MATLAB is a registered trademark of the Mathworks Inc.
Peel 3D is a trademark of Creaform Inc.
FARO is a trademark of FARO technologies Inc.
Akrapovic is a trademark of Igor Akrapovic.

Vehicles show may be prototypes, and/or with options. Actual models may vary. Colors depicted may vary based on multiple factors, including ambient lighting and the format in which they are being viewed (e.g. computer, mobile device, or print). See your local dealer for details. For more information call +30 210 60 25 003 or visit aurora-rally.com.

DISCLOSURES



Dealer Network



USA Importer



Australian Importer

The new DesertX kit is available from our online store www.aurora-rally.com or from our authorised dealers across the world.

The **full** kit consists of:

- Carbon Fiber Fuel Tank with SLS Forced Direct Intake and two stage air filtering.
- Carbon Fiber front side panels.
- Twinair net to ensure that the air from the intake does not pollute the air filters.
- Choice of a carbon fiber glove box to replace the intake and different air filter covers to protect the air filter or force air into it.
- Speedo relocation bracket with harness extension.
- Monoblock navigation tower with adventure back plate.
- Carbon Fiber Tank protectors (an extra, removable layer).
- Fuel tank cap (keyed or key-less - user choice).
- Billet, Two way breather with Tygon hose.
- Two high quality DNA High performance air filters (one for each stage)
- OEM or Off-road LP4 lights (User choice).

Make sure that you check with certain federal, state and local laws, rules and ordinances relating to vehicle operated on public highways, pollution e.t.c. Check the applicable laws before modifying your motorcycle. Trademarks and logos of third parties used on this brochure are exclusive property of the respective owners.

EICMA 2023 - DesertXpress - RC3 - © Aurora Rally Equipment IKE, 2023. Copying, distributing, modifying or sharing any content except as provided above is expressly prohibited without prior written permission.



Aurora Rally Equipment PLC

19th km Spaton - Loutsas Av.

19004 Spata, Greece

Tel: +30 210 60 25 003

email: info@aurora-rally.com

web: aurora-rally.com